

22020159 (SAP- 40621125) (ETL No- 53BHN00202) - TECHNOLOGY TRANSFER

Before-Current Manufacturing Technology - TRMI

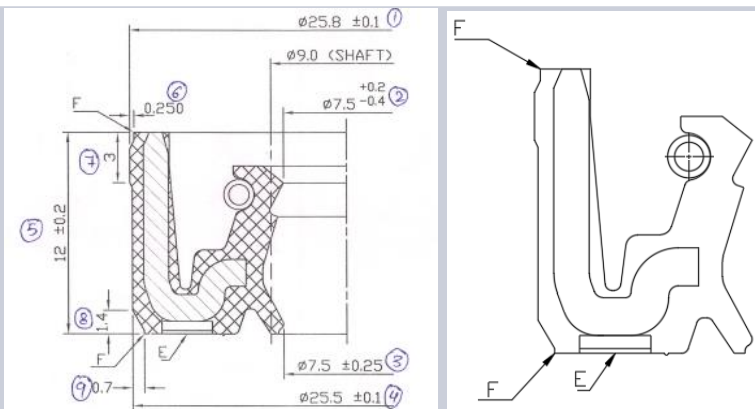

After-New Proposed Technology - CM 150T 2RT

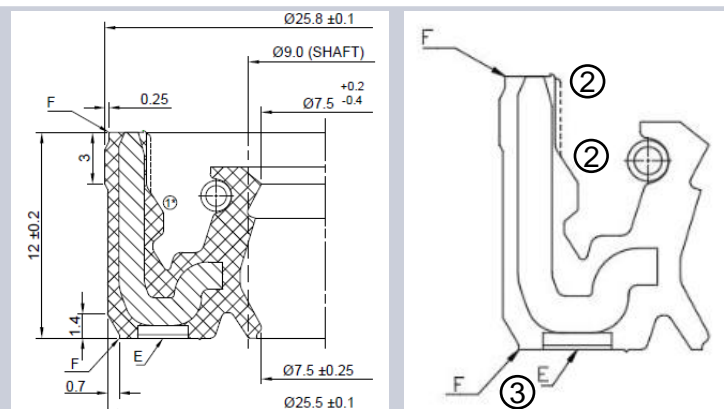

Points considered during the change from TRMI to CM:

1. No changes in the Major dimension or the profile of the part, which are related to the performance of Seal.
2. For process Improvement Side chaplets and Part retention step provided.
3. Engraving changed from "SFN 090-03-ID cav. No. ETPL" to "FNI 090-03-ID ETPL CAV. No"

Reasons :

1. Manufacturing process stabilization.
2. Process Automation.