

|              |                       |
|--------------|-----------------------|
| Process Name | End Connector Process |
| Part No.     | P2 5000007            |
| Part Name    | End Connector 50°     |

**PROCESS FLOW DIAGRAM**

| SUNREN AUTOMOTIVE PVT. LTD., ROORKEE |                  |             |
|--------------------------------------|------------------|-------------|
| Approved by                          | Checked By       | Prepared By |
| Dharmbir Saini                       | Rajeev Srivastva | Shivank     |

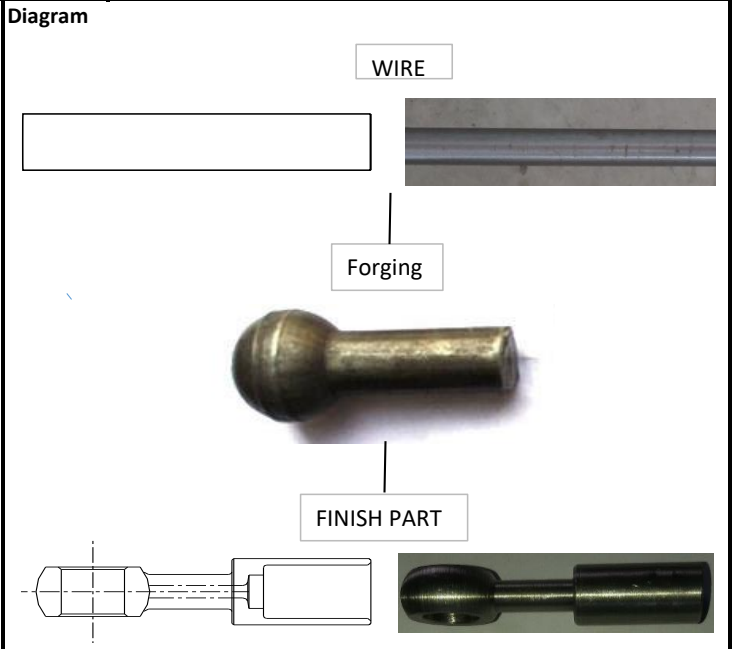
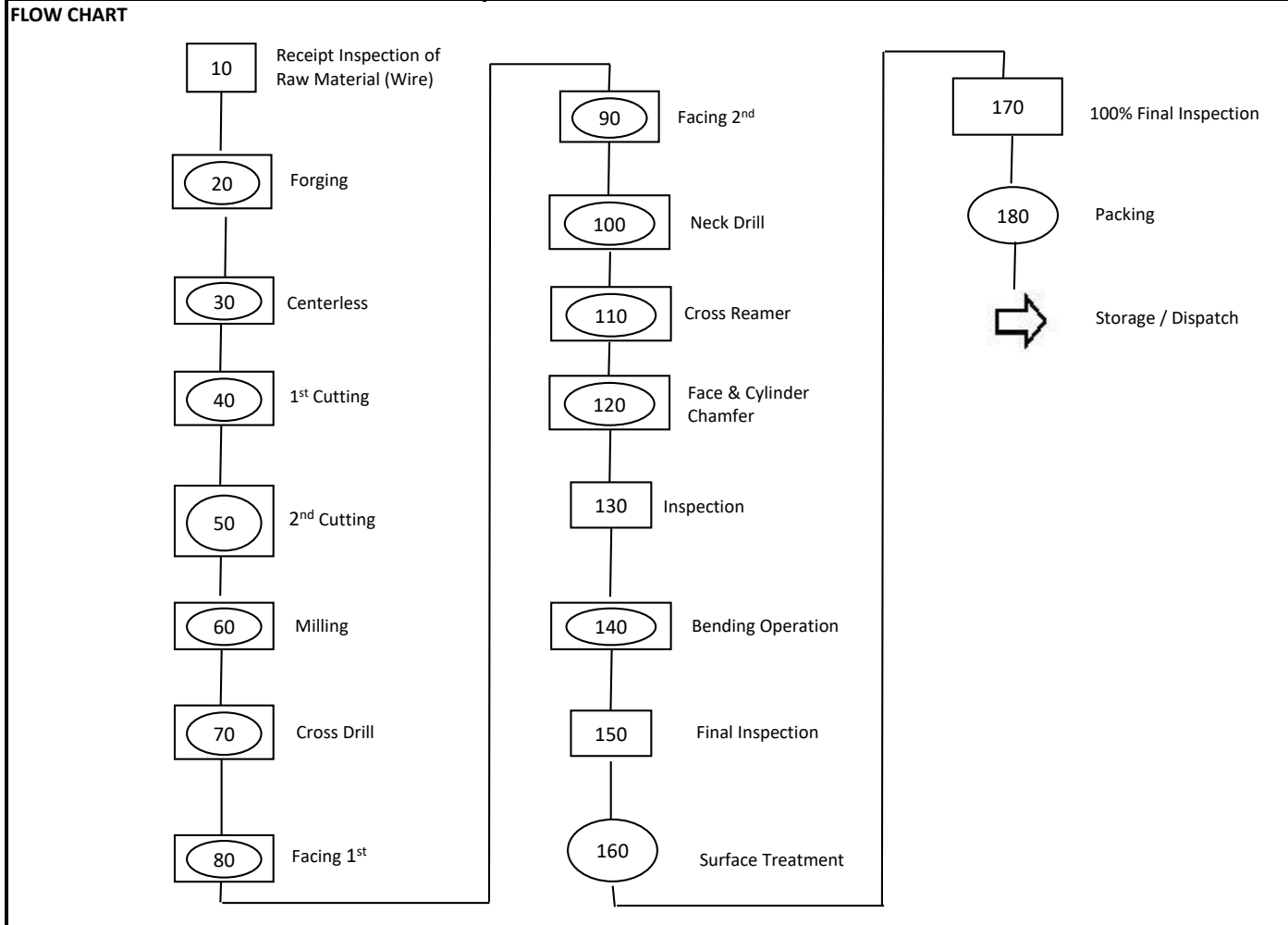

| 2       | 27.07.2023 | 01              | Shivank          |
|---------|------------|-----------------|------------------|
| 1       | 26.02.2017 | 00              | Rajeev Srivastwa |
| Sr. No. | Date       | Revision Record | Approved By      |

| Operation | Quality Inspection | Storage | Transportation | Operation Cum Inspection |
|-----------|--------------------|---------|----------------|--------------------------|
| ○         | □                  | ▽       | ➡              | ○□                       |