

10 9 8 7 6 5 4 3 2 1

550FJ03202

- THE INFORMATION CONTAINED HEREIN IS STRICTLY CONFIDENTIAL - CRITICAL AND IS A PROPERTY OF ENDURANCE SUSPENSION DIVISION, AURANGABAD AND ANY USE EXCEPT THAT FOR WHICH IT IS AUTHORISED IS STRICTLY PROHIBITED. ANY MISUSE OR INFRINGEMENT THEREOF WILL RESULT IN LEGAL ACTION TO PROTECT OUR RIGHTS. IF YOU ARE NOT THE INTENDED RECIPIENT/YOU HAVE RECEIVED THIS IN ERROR PLEASE DONOT REVIEW OR COPY THIS DOCUMENT AND KINDLY NOTIFY AT THE MENTIONED ADDRESS. - ITEM CODES ENDING WITH 'O' REPRESENTS DRAWINGS. CORRESPONDING PART NOS/CODES WILL END WITH 'M' OR 'B' BASED ON COMPANY'S MAKE OR BUY DECISION.

F  
E  
D  
C  
B  
A  
 ALL DIMENSIONS ARE IN mm (IF NOT SPECIFIED)  
 ASK IF IN DOUBT

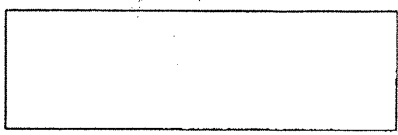
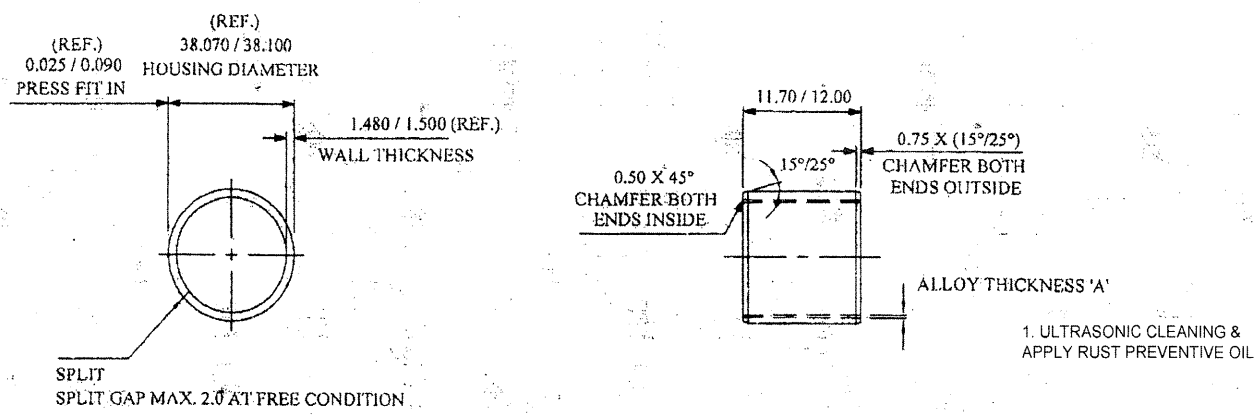

DEVELOPED VIEW

SPECIFICATIONS	
MATERIAL	DDK02
ID SURFACE TYPE	PLAIN
SEAM TYPE	PLAIN
PLATING	TIN FLASH
EQUIVALENT SIZE O.D.	
GO	38.150
NO GO	38.110

- LAYER THICKNESS:
- STEEL = REMAINDER
  - ALLOY (A) = 0.20/0.40
- NOTE:
- ALL SURFACES EXCEPT DDK02 SURFACE TO BE TIN FLASHED.
  - STAMPING MARK ON BACK METAL AS FOLLOWS: DAIDO MARK, MATERIAL CODE, LOT NO.
  - BUSH TO BE ASSEMBLED IN RING GAUGE OF 38.085 AND ID TO BE CHECKED BY GO / NO GO PLUG GAUGE OF 35.085 / 35.115
  - BUSH ID AFTER ASSEMBLED IN HOUSING 35.070 / 35.130 (Ref.)
  - FORK PIPE DIA 34.950 / 34.980 (REF.)
  - OIL CLEARANCE 0.090 / 0.180 (REF.)

REV	MOD	DATE	REMARKS	PRE	CHKD	APPD

**BBL DAIDO PRIVATE LIMITED**

CUSTOMER: **ENDURANCE SYSTEM (I) PVT LTD**

PART: **BUSH**

ISSUE	1	A3	1 OF 1	BD REF No	-
DATE	14.02.09	SCALE	NONE	BD DRAWING No.	-
KVS		PART No.	TO BE ALLOTTED	BD DRAWING No.	-
DRAWN	CHKD	APPD			

MODEL	PCS/SET
~	~

UNLESS OTHERWISE SPECIFIED ALL DIMENSIONS ARE IN MM EDGES TO BE FREE FROM BURRS

GENERAL TOLERANCE ± 0.25

ANGLE ± 5°

GENERAL FINISHING ✓ 25

SAFETY CHARACTERS	● = 0
SIGNIFICANT CHARACTERS	○ = 0

MATERIAL	-	DESCRIPTION	GUIDE BUSH C5 (∅ 35x12)
WEIGHT	- gms	DRG. No./PART No.	550FJ03202
VOLUME	- mm <sup>3</sup>	REV	B
SURFACE AREA P/C OR PLTG	- mm <sup>2</sup>	SCALE	NTS
PROJECTION ANGLE		SHEET NO.	1 OF 1
DATE	02.02.24	REVISION	B
REV	B	ALTERATION	TIN FLASH COATING REMOVED IN ETL TEMPLATE
DATE	06.03.19	ALTERATION	RELEASE FOR PRODUCTION
REV	A	ALTERATION	NEW RELEASE
DATE	16.02.09	ALTERATION	
REV	XA	ALTERATION	
DATE		ALTERATION	
REV		ALTERATION	

NOTE: 1. UNSPECIFIED TOLERANCES AS PER IS-2102 (PART-1) MEDIUM  
2. DO NOT SCALE (REFERENCE ONLY)

mm 0 4 8 12 16 20 30 40 50 60

SIZE: A3

ENDURANCE SUSPENSION DIVISION  
E-92, MIDC WALUJ, AURANGABAD (M. S.)-431136, INDIA  
Ph.: +91-240-2554902, 25564595. Fax.: +91-240-2555423