



CHECKLIST
BREAKER MACHINE

Name of Project: Kohler India Pvt. Ltd.

Identification No.: 01

Location: Main plant, pump house.

Date: 05-04-2024

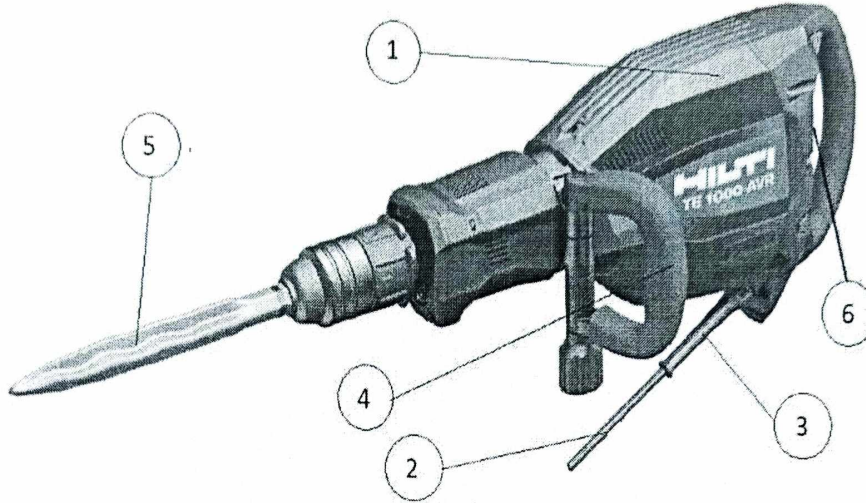

Sr. No.	Descriptions	Ok	Not Ok	NA	Remark
1	Breaker should be in good and working condition.	OK			
2	Power cable should be free from damages and connection taken through industrial plug.	OK			
3	A flexible cord should be provided to keep cable free from damage.	OK			
4	Handle should be provided for better control.	OK			
5	Bit should be in good condition and free from defect.	OK			
6	Breaker should be double insulated	OK			
7	Machine operated by competent person.	OK			
8					
9					

Overall Remarks, if any: _____

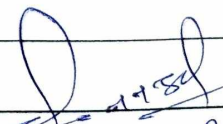
Name & Sign of Safety Officer: DANISH ANWAR 

Name & Sign of Project Manager/ Engg: Hussain S A 

05-04-2024

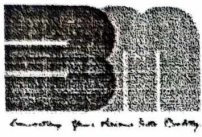

CHECKLIST

CONCRETE VIBRATOR

Doc.No.	BMCPL-EHS-CL-25
Rev.No.	00
Date	01 Jan 2022
Page	1 of 1

Name of Project: - Kohler India Pvt. Ltd. Identification No.: - 05
 Location: - Main Plant, Pump House. Date: - 05-04-2024

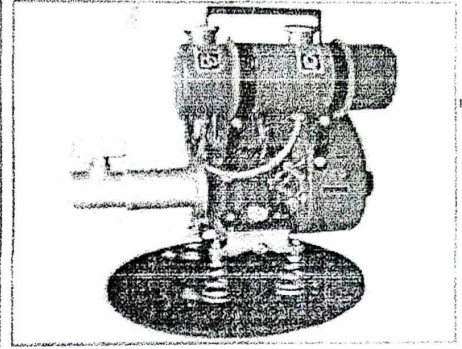
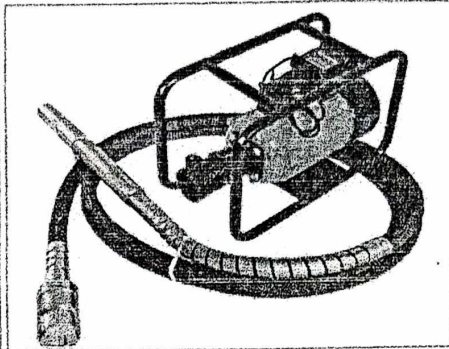
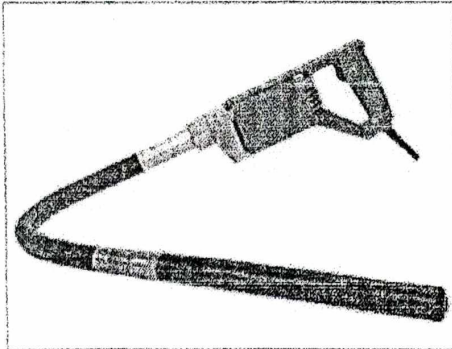

Type of Vibrator

Handheld Electric Power Operated	Portable Electric Power Operated	Portable Fuel-Oil Operated
✓		

Sr.No.	Descriptions	Ok	Not Ok	NA	Remark
1	Authorized operator with Proper PPE's	ok			
2	Motor casing without any damage	ok			
3	Sheathed 3-core cable with cable top	ok			
4	Power connection made through ELCB	ok			
5	Protected starter box and on/off switch condition	ok			
6	Motor with protected power terminal box	ok			
7	Protective guard on moving parts	ok			
8	Vibrator case and frame/bottom condition	ok			
9	Protected fuel tank without leakage			N/A	
10	Fuel pipe without damage and spillage			N/A	
11	Healthy needle hose and coupling	yes			
12	Safe location for positioning vibrator	yes			

Overall Remarks, if any: - _____

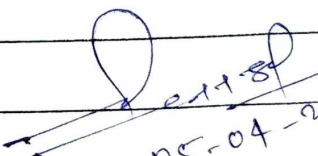
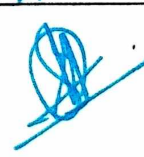
Name & Sign of Safety Officer: DANISH ANWAR 
 Name & Sign of Project Manager/Engg: Hussain S.A 

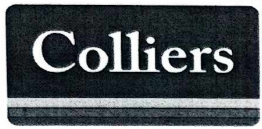

EARTH PIT INSPECTION

Name of Project: Kohler India Pvt. Ltd.

Date of Inspection.: 02/05/2024

Sr. No.	Location	Earth Pit Number	Resistance Value in Ohms	Date of Inspection	Next Inspection date	Test Remarks	Signature of Authorized Electrician
1	Main Panel-01 Fabrication Yard	Earth Pit-01	0.92 Ω	02.05.2024	01.06.2024	OK	<i>[Signature]</i>
2	Colliers Office	Earth Pit-02	0.91 Ω	02.05.2024	01.06.2024	OK	<i>[Signature]</i>
3	Sub Panel Main Plant	Earth Pit-03	0.79 Ω	02.05.2024	01.06.2024	OK	<i>[Signature]</i>
4	DB-03 Main Plant	Earth Pit-04	0.17 Ω	02.05.2024	01.06.2024	OK	<i>[Signature]</i>
5	DB-05 Main Plant	Earth Pit-05	0.25 Ω	02.05.2024	01.06.2024	OK	<i>[Signature]</i>
6	Portable DB-03 Pump House	Earth Pit-06	0.80 Ω	02.05.2024	01.06.2024	OK	<i>[Signature]</i>
7							
8							
9							
10							

Overall Remarks, if any: - _____

BMCPL EHS Representative Name & Signature: DANISH ALWAR *[Signature]* 02/05/2024

COLLIERS EHS Representative Name & Signature: Hussain S. Attar *[Signature]*