



AMBIT

providing peace of mind....



Company Profile

AMBIT is a one-point destination for addressing your Electronic Security & Fire Safety concerns. Having studied the Electronic security & Fire Safety Solutions market in detail, we have realized a growing concern for security throughout the country , and the need for a reliable, customer oriented service provider who can take care of these concerns.

Our efficient and highly experienced team of employees are dedicated to supporting our customers through delivery on-time and on-budget solutions. Backed by our maintenance and service support teams you can be assured that we will be able to secure and protect your investments for many years to come.

Keeping this aim in mind, we have tied up with top of the line international standard security equipment manufacturers. Each of our comprehensive range of products are designed and tested for local standards and conditions. Whether for life safety and protection or special uses , each of the products is tested thoroughly for quality.



Nature of Business:

AMBIT is in the business of providing customers with a peace of mind through innovative, affordable security solutions backed by technical support.

We have experience of more than 8 years in doing projects with the top construction houses, technology companies, government premises, Banks in Mumbai & data centers for their major projects.

We continuously strive to upgrade our product and service line to make your neighborhood a safer place.



Prime Activities

AMBIT brings with it the technological advancements from the worldwide market combined with a team of professionals with thorough knowledge and experience of the local market.

Understanding the concerns, needs and services required both in the residential as well as the corporate industry.

Ambit supplies, installs, designs and maintains products and systems of everything related to electronic & fire safety .

We have tie-up with license agency for Certification and Liasoning purposes.

CCTv camera systems, with digital video recording systems and Remote digital surveillance systems

The entire premises can be monitored locally as well as remotely using High Definition and IP Cameras and IP Addressable Recording Devices. Also extremely large premises can be covered using our wireless Transmitter/ Receiver Systems.



Access control systems

Important Areas can be restricted for employees as per their respective functions and Premise entries can be restricted for visitors using card based, Fingerprint, Face Reading, Mobile Readers. Also time attendance reports can be generated for the employees using this systems.



Rodent Repellent Systems

The premises can be made rodent free using this systems which emit continous ultrasonic sound to make the rodents leave the premises and also prevents further pro-creation.



Fire Alarm systems

The premises can be made alert to fire mishaps by installing these fire alarm systems which can be addressable or conventional and can alert the occupants of the premises in case of fire, so that the necessary steps can be taken to prevent the spreading of the fire. Heat Detectors can be installed in Pantry and electrical areas and smoke detectors can be installed in general areas and Beam Detectors in High Ceiling areas.



Sprinkler systems.



This systems can be installed in general premises to douse the fire by spraying highly pressured water in areas where electrical equipments are not present.

Fire Extinguishers / FM200/ Novec Gas Based Fire Suppression systems

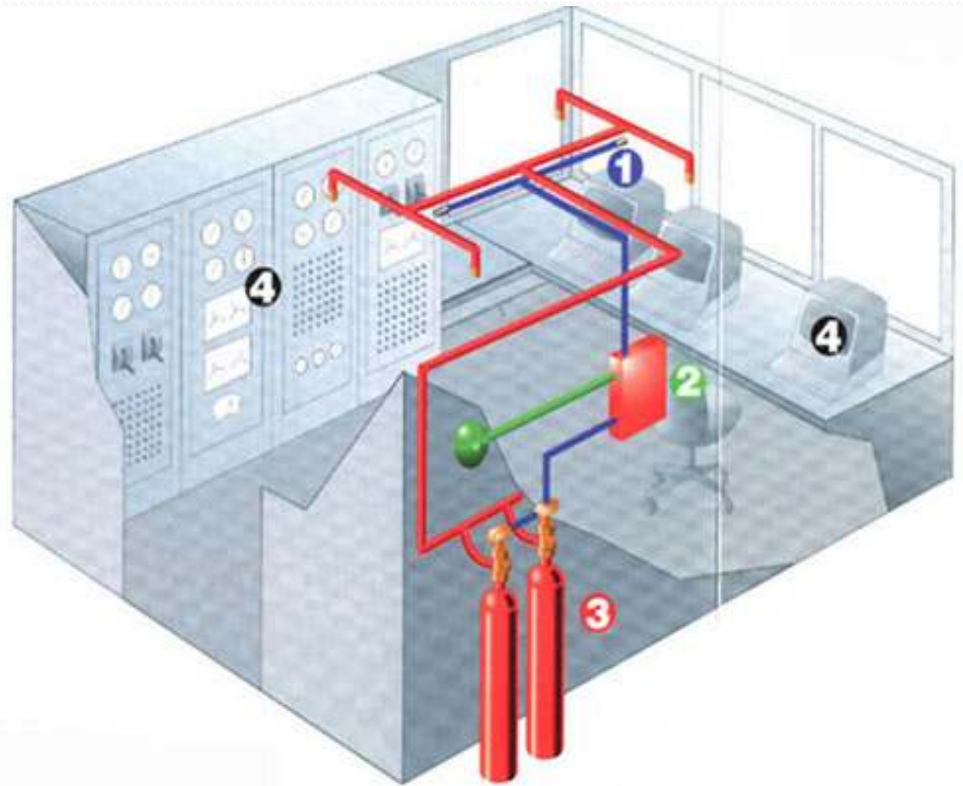

FIRE SUPPRESSION SYSTEMS / NOVEC

Novec™ 1230, manufactured is a unique fire extinguishing agent. Among the Clean Agents, it has the lowest atmospheric lifetime of 5 days. It is stored as a liquid, which makes it easier for transport, and also has a "zero ozone depletion potential". As with other clean agents, it is an excellent choice for computer rooms, electrical control rooms, storage areas, and any high value area. Novec is calculated to discharge within 10 seconds, and is normally calculated at a 4.2% concentration

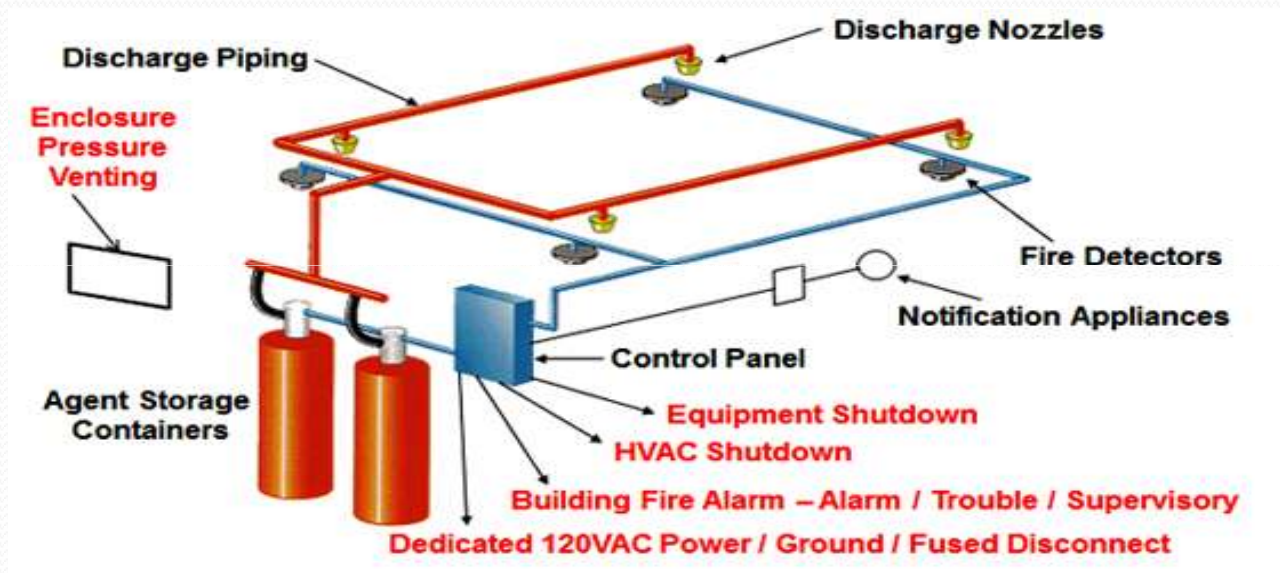

Novec Systems are used in Data Center areas and electrical areas to suppress fire using Clean Agents. Less environmental friendly systems called as FM200 are used in Premises where there is a possibility of Human presence more often than not. Gas calculations are as per Premise Dimensions.

VESDA- VERY EARLY SMOKE DETECTION ALARM THROUGH AIR SAMPLING



This can be the first level of fire security in premises where the air would be sampled continuously using suction pipes which pull the air into the aspiration detector. Even minimal amount of smoke would give a warning alarm , so that the premises can be checked. This can be installed in all critical areas.

WATER LEAKAGE DETECTION SYSTEMS

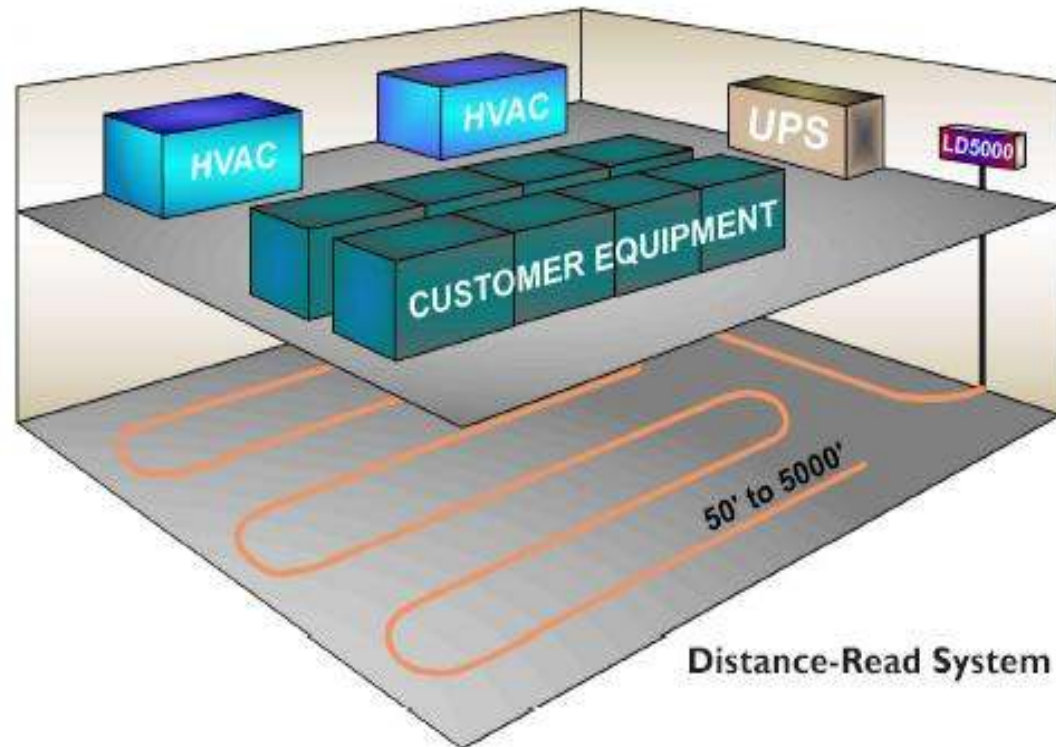

Any leakage in the premises due to air condensation or due to any other reasons will be detected by water leakage detection cables laid out to cover the corners and other vulnerable areas this can be installed in Data Centers.



Innovations

AMBIT is constantly acquiring new products to meet our customers' ever growing need for life safety products and solutions from top-line electronic safety equipment manufacturers worldwide. We work hard to ensure that these products are not only the best available in terms of performance and quality, but also cost effective in this competitive market.

As aiming to be one of the top security and services company, Ambit makes use of its extensive experience and latest available technology to offer the best security solutions for any type of risk. From the smallest residence to the largest commercial building, we offer a wide range of products and services.

Its our Endeavour to provide the customer whatever he requires to stave off his security concerns with the best of equipment and best of service.



Mission Statement :

To be the leading National Security & Safety solution provider by continuously endeavoring to make the neighborhoods a safer place.

Company's Vision :

To ensure total Customer Satisfaction resulting in customers peace of mind by understanding the specific safety needs of each & every one of our customer & providing appropriate & state-of-the-art electronic & fire safety solutions.

Brief Details of Few Projects completed by AMBIT :

Sr.No.	Company name	Project details	Location
1	Endurance Technologies Ltd	a) Fire Alarm System b) Biometric Access Control System c) VESDA system d) Novec1230 Gas Suppression System e) Water Leakage detection system f) Rodent Repellent System	<u>Chakan, Pune</u>
2	Marsh India Insurance Brokers Pvt Ltd	a) Fire Alarm System b) Access Control System c) Water Leakage Detection System d) Sprinkler system for the office e) CCTV system	<u>PAN India</u>
3]	India Today	a) Fire Alarm System b) Access Control System c) Water Leakage Detection System d) Sprinkler system for the office e) CCTV system f) FM200 Gas suppression System	<u>Lower Parel, Mumbai</u>
4]	Axis Bank	a) Rodent Repellent System b) Novec1230 Gas Suppression System c) Water Leakage Detection system d) VESDA system	<u>Airoli, Navi Mumbai</u>
5]	Mahindra & Mahindra	Migration & Re-commissioning of : a) FM200 Gas suppression system b) Water Leakage Detection system c) Fire Alarm System	<u>Kandivali, Mumbai</u>
12]	ALD Automotive Ltd	a) Fire Alarm System	Kurla, Mumbai

6]	India First Insurance Company Ltd	PAN India AMC of : a] CCTV system b] Fire Alarm System	<u>PAN India</u>
7]	Financial Planning Standards Board of India	a] Sprinkler system for office b] Fire alarm system c] CCTV system d] Access Control System	<u>Andheri, Mumbai</u>
8]	DH consultants India	a] Sprinkler system for office b] Fire alarm system c] CCTV system d] Access Control System	<u>Andheri, Mumbai</u>
9]	Rallis India Ltd	a] Fire Alarm system b] Biometric access Control system	<u>Belapur, Navi Mumbai</u>
10]	NSE-IT	a] Fire Alarm system	<u>Andheri, Mumbai</u>
11]	Magic 9 Media Analytics	a] Biometric Face Reading access control b] CCTV system	<u>Chinchpokli, Mumbai</u>
12]	ALD Automotive Ltd	a] Fire Alarm System	<u>Kurla, Mumbai</u>
13]	Microtrol Ltd.	a] CCTV system	<u>Mhape, Navi Mumbai</u>
14]	Legrand India	a] Access control system	<u>PAN India</u>



CONTACT US

AMBIT ELECTRONIC SECURITY SERVICES

A-106, Plot No..13, Kukreja Centre,

Sector-11, CBD Belapur,

Navi Mumbai-400614

Email: hkotian@ambit-india.net , accounts@ambit-india.net

Website: www.ambit-india.net

Office Tel: 022 41277444 / 022 65026320

Mobile: Mr. Hemant Kotian - 9819486309