

DATE	REV.	MOD	ALTERATION	CA
07/02/2023	XA	00	NEW RELEASE	----
28/03/2023	XA	01	DIMS 21.8, 8.7, 11.2 WAS 21, 8.8, 10.5 CHANGES DENOTED BY \triangle	5764

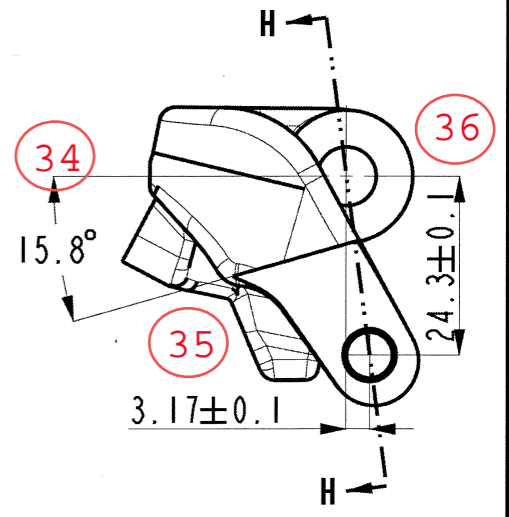
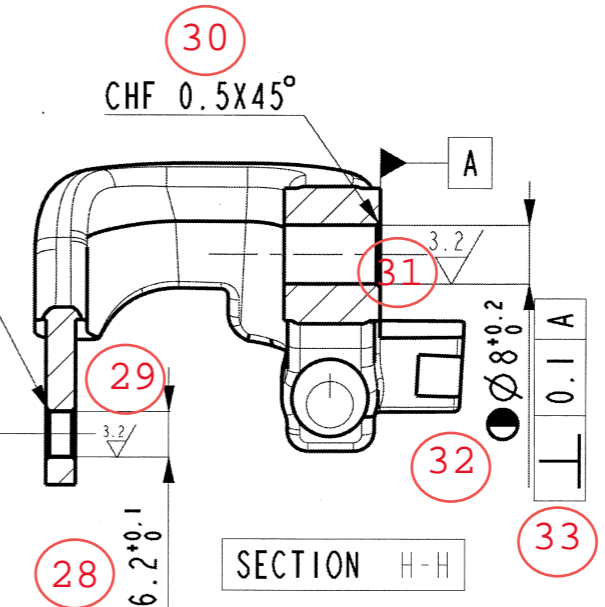
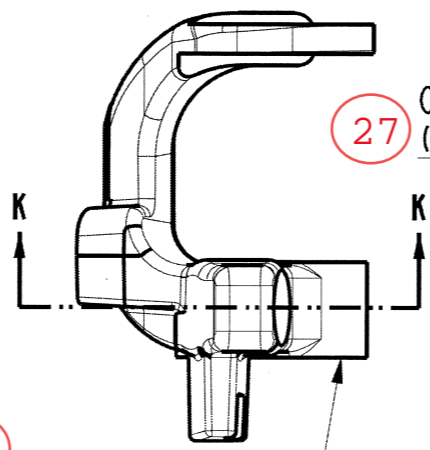
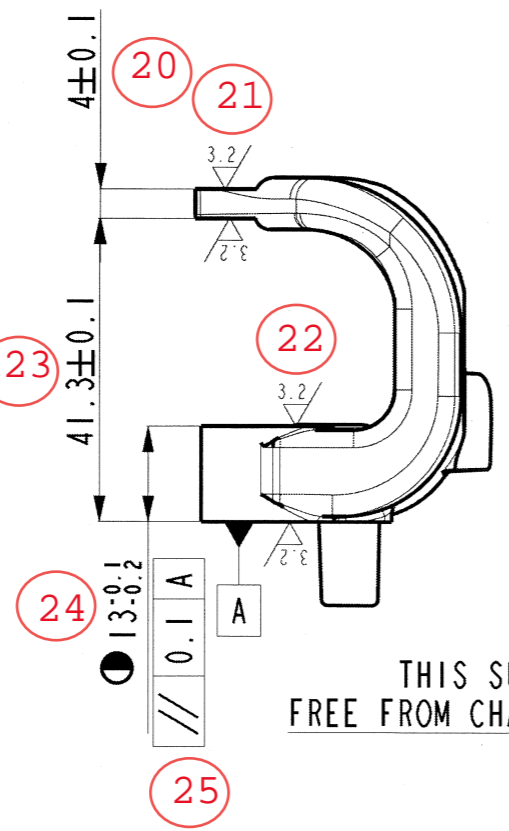
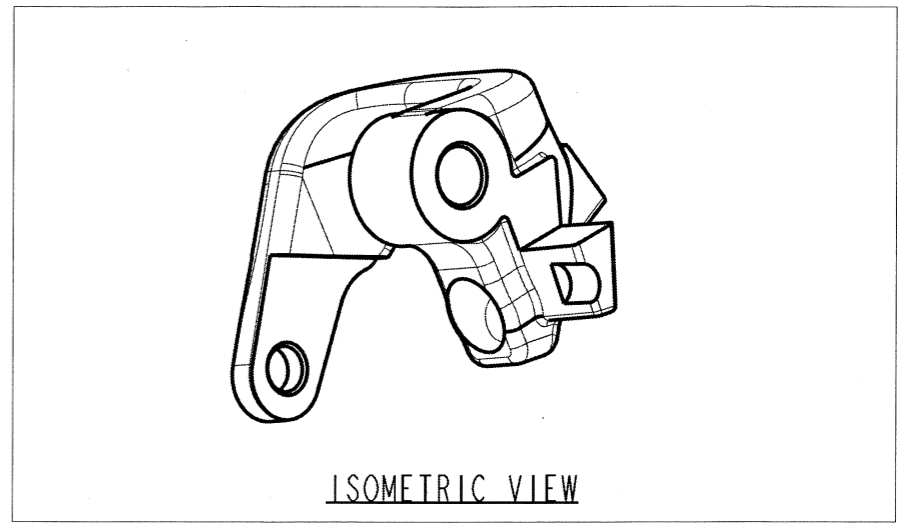
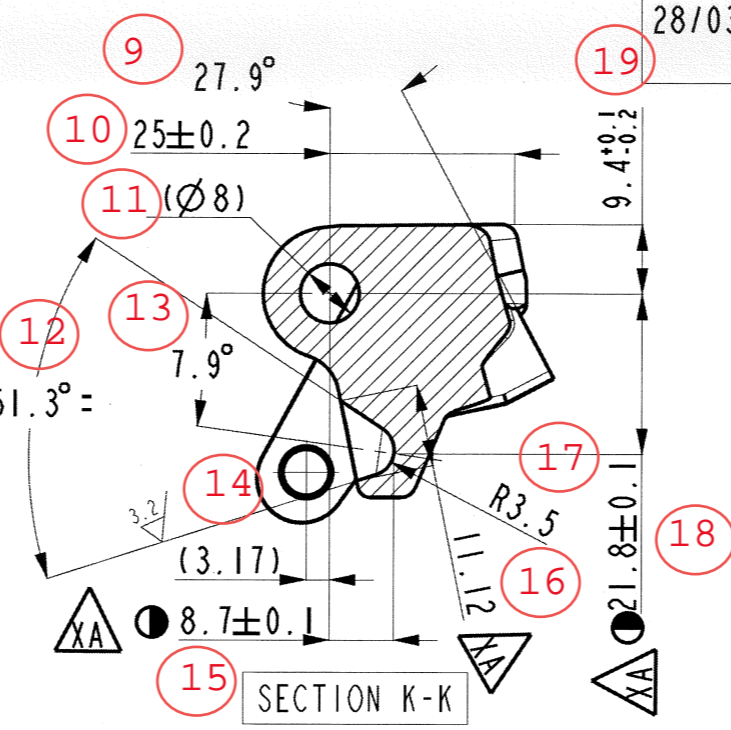
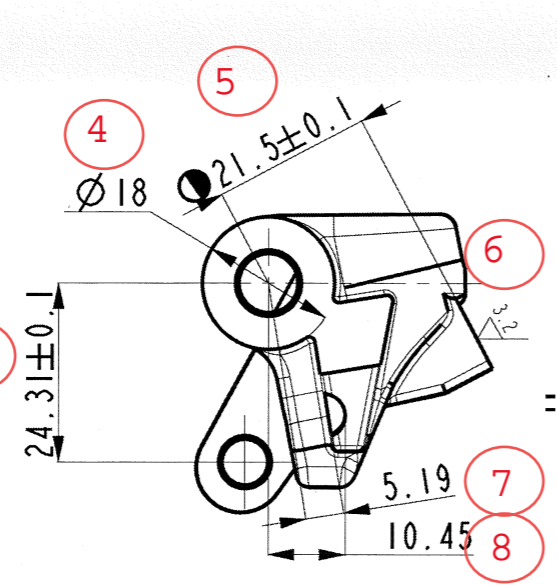
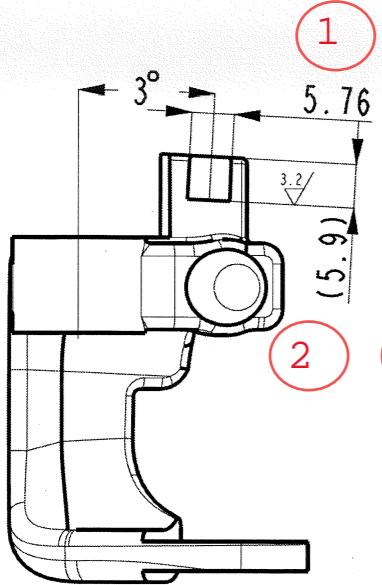

THIS SURFACE SHOULD BE FLAT & FREE FROM CHATTER MARKS & WAVINESS.

PART NUMBER
POWDER COATING B2BP039230

MASTER COPY

+	POSITION TOLERANCE FOR OPEN DIMENSIONS
?	SHAFTS
?	H : FROM A TO HOLES
?	H : FROM A TO HOLES
+	SHEET SIZE
+	SIGNIFICANT
+	SAFETY

- NOTES:
1. FINISH: PURE POLYESTER POWDER COATING AS PER ABS00012. (37)
COLOUR: SATIN BLACK FINISH.
 2. BRAKE LEVER MACHINED PART NO. B2BP039060 (38)
 3. POWDER COATING TO BE DONE BEFORE MACHINING (39)
 4. SURFACE SHALL BE SMOOTH.
BUFFING DEFECTS, WAVINESS, POWDER COATING DEFECTS NOT ALLOWED. (40)

● = 4	SCALE: 1:1	MATERIAL: LM 6	O.E. PART NO. JZ161074
● = 0		4600 AS PER IS:617 (41)	RAW DWG NO. B2BP039030
DRAWN SST		OR	DRG. REV. XA MOD.01
CHECKED RSP		GAISI 13 AS PER UNI 4514	DWG/PART NO. B2BP039000
APPROVED PMK		PART NAME: SECONDARY LEVER FINISHED U101 CBS	
TOLERANCES	RAW WEIGHT: 57.7 gms	FINISHED WEIGHT: ~ 47.4 gms (42)	
	FINISH:		
	HEAT TREATMENT:		
ENDURANCE TECHNOLOGIES LTD. BRAKING DIVISION			