

SUPERSEDS-			
DATE	REV	ALTERATION	CR
15/02/2020	XA	NEW RELEASED	PDRN-26

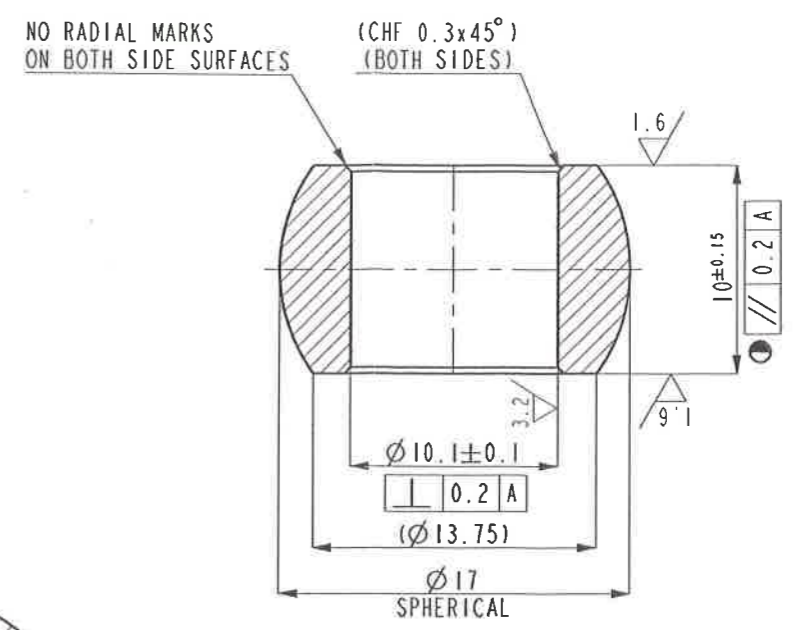

SECTION B-B
SCALE 4:1

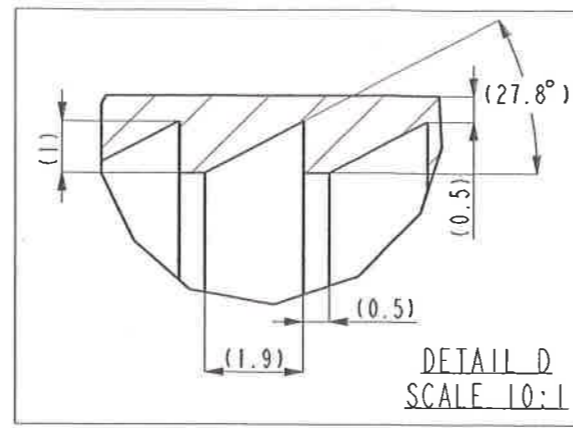
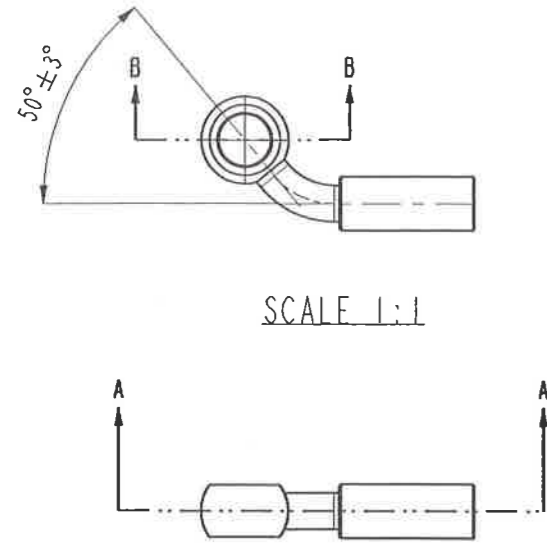
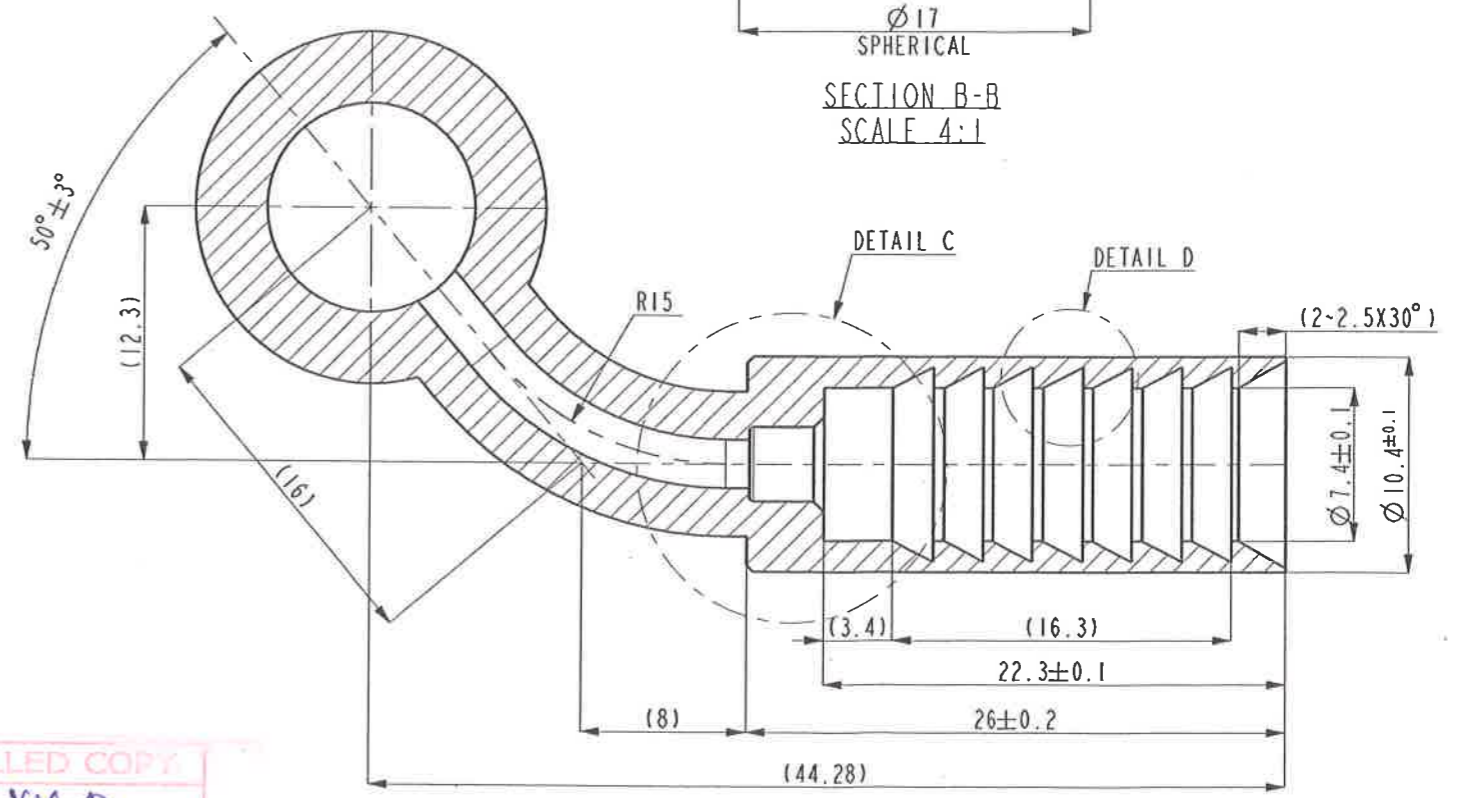
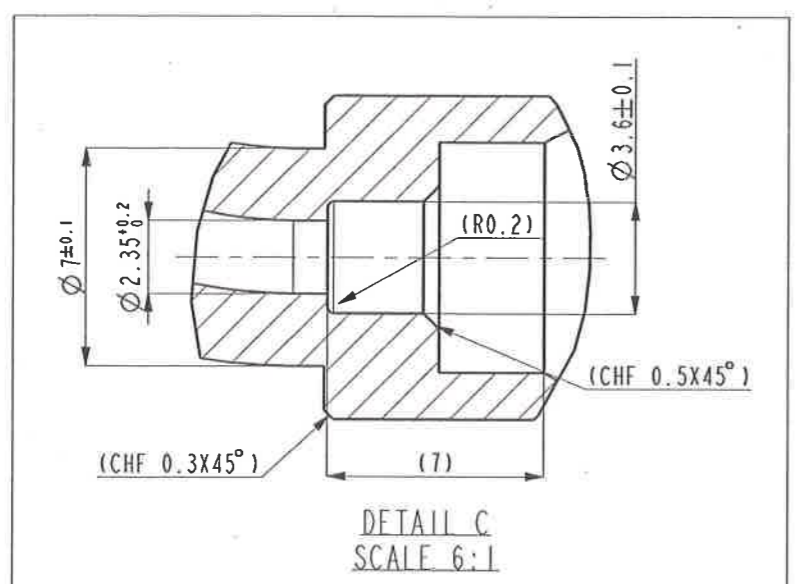

SECTION A-A
SCALE 4:1

Provisional Drawing
Release

CONTROLLED COPY
Issued To: V.C.D
Date: 29/02/2020

- NOTES:
1. SURFACE TREATMENT FOR END CONNECTOR: Fe/Zn (WHITE) AS PER ABS00010 TO BE DONE AFTER BRAZING.
 2. PART SHALL BE FREE FROM BURRS.
 3. ENSURE THAT OPENING OF DRILLED HOLE Ø2.35 IN BANJO.
 4. ALL DIMENSIONS TO BE MEASURED AFTER PLATING.
 5. BRACKET () DIMENSIONS ONLY FOR REFERENCE.

<table border="0"> <tr> <td>☉ = 1</td> <td>SCALE:</td> <td>MATERIAL:</td> <td>O.E. PART NO.</td> </tr> <tr> <td>● = 0</td> <td>4:1</td> <td>ENIA/15B25/C20</td> <td>NA</td> </tr> <tr> <td>DRAWN SST</td> <td><i>[Signature]</i></td> <td>PART NAME:</td> <td>RAW DWG/PART NO</td> </tr> <tr> <td>CHECKED PMK</td> <td><i>[Signature]</i></td> <td>END CONNECTOR-STEEL BRAIDED HOSE (ABS UNIT SIDE)</td> <td>NA</td> </tr> <tr> <td>APPROVED MRD</td> <td><i>[Signature]</i></td> <td></td> <td>XA</td> </tr> <tr> <td>TOLERANCES</td> <td>RAW WEIGHT: N.A.</td> <td>FINISHED WEIGHT: ~21 gms</td> <td>DWG/PART NO.</td> </tr> <tr> <td></td> <td>FINISH: REFER NOTE</td> <td></td> <td>B2EH077020</td> </tr> <tr> <td></td> <td>HEAT TREATMENT: N.A.</td> <td></td> <td></td> </tr> </table>	☉ = 1	SCALE:	MATERIAL:	O.E. PART NO.	● = 0	4:1	ENIA/15B25/C20	NA	DRAWN SST	<i>[Signature]</i>	PART NAME:	RAW DWG/PART NO	CHECKED PMK	<i>[Signature]</i>	END CONNECTOR-STEEL BRAIDED HOSE (ABS UNIT SIDE)	NA	APPROVED MRD	<i>[Signature]</i>		XA	TOLERANCES	RAW WEIGHT: N.A.	FINISHED WEIGHT: ~21 gms	DWG/PART NO.		FINISH: REFER NOTE		B2EH077020		HEAT TREATMENT: N.A.			<p>ENDURANCE TECHNOLOGIES LTD. BRAKING DIVISION</p>		
☉ = 1	SCALE:	MATERIAL:	O.E. PART NO.																																
● = 0	4:1	ENIA/15B25/C20	NA																																
DRAWN SST	<i>[Signature]</i>	PART NAME:	RAW DWG/PART NO																																
CHECKED PMK	<i>[Signature]</i>	END CONNECTOR-STEEL BRAIDED HOSE (ABS UNIT SIDE)	NA																																
APPROVED MRD	<i>[Signature]</i>		XA																																
TOLERANCES	RAW WEIGHT: N.A.	FINISHED WEIGHT: ~21 gms	DWG/PART NO.																																
	FINISH: REFER NOTE		B2EH077020																																
	HEAT TREATMENT: N.A.																																		

This drawing is a property of Endurance Technologies Ltd. and shall not be copied or reproduced without permission of the company. FIRST ANGLE PROJECTION - PLEASE DO NOT SCALE THE DRAWING. ASK IF IN ANY DOUBT - ALL DIMENSIONS IN mm.

SAFETY SIGNIFICANT

SHEET SIZE A2

SHAFTS HOLES FROM 0 TO 4