

DATE	REV.	ALTERATION	CA
13/05/2021	XA	NEW RELEASE	CA-2028
30/08/2021	XB	DIMENSION CHANGED DIA 18mm WAS DIA 17 mm, CHANGES DENOTED BY	CA-2807

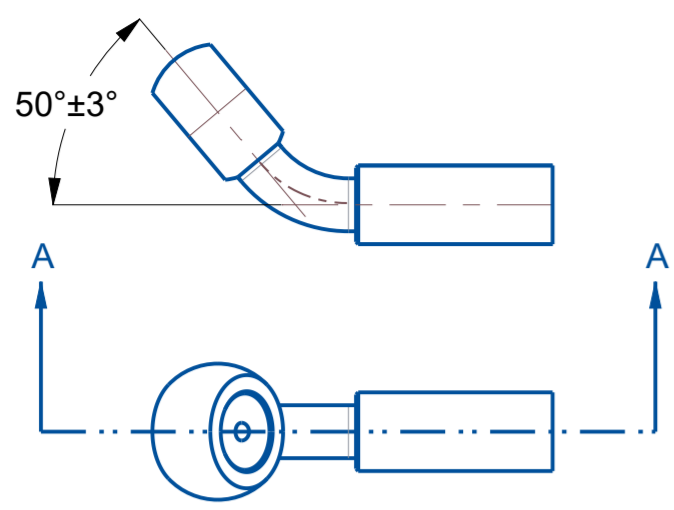

SCALE 1:1

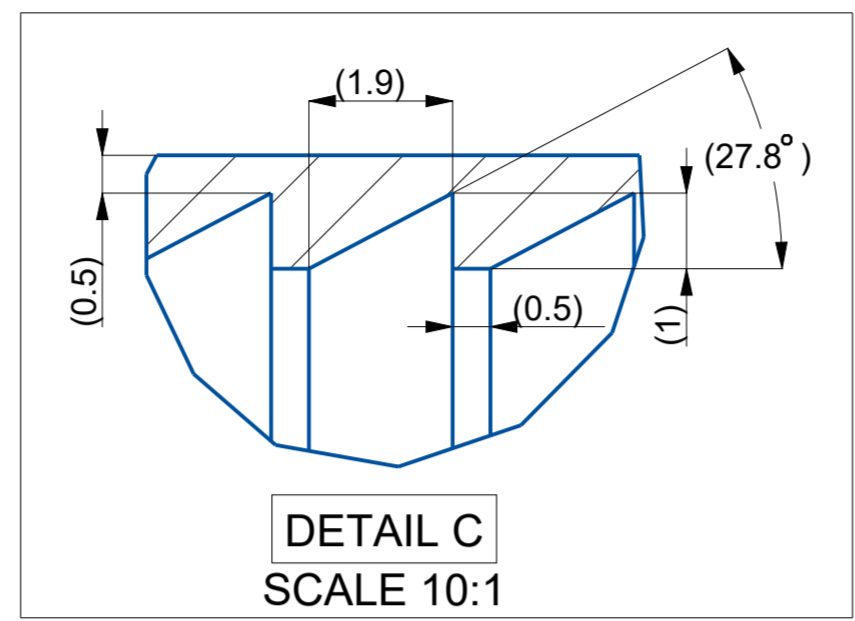

DETAIL C  
SCALE 10:1

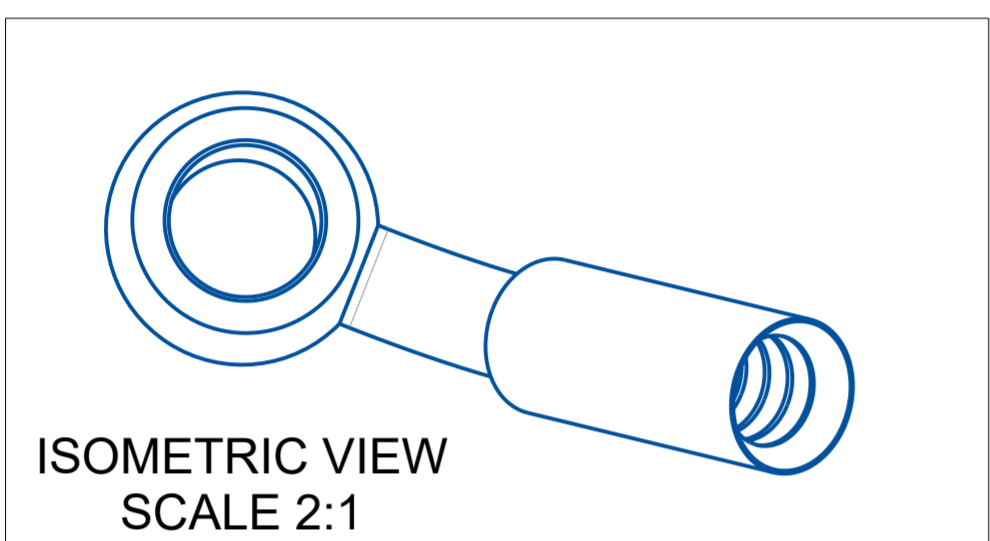

ISOMETRIC VIEW  
SCALE 2:1

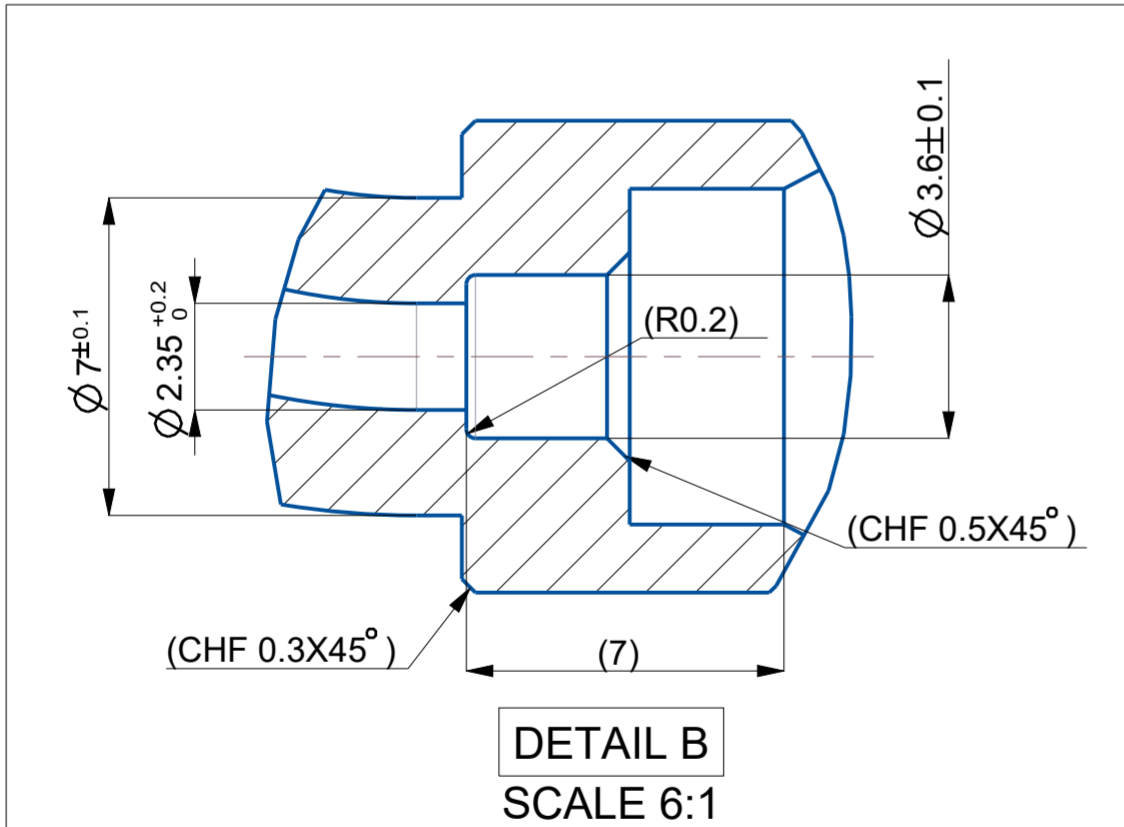
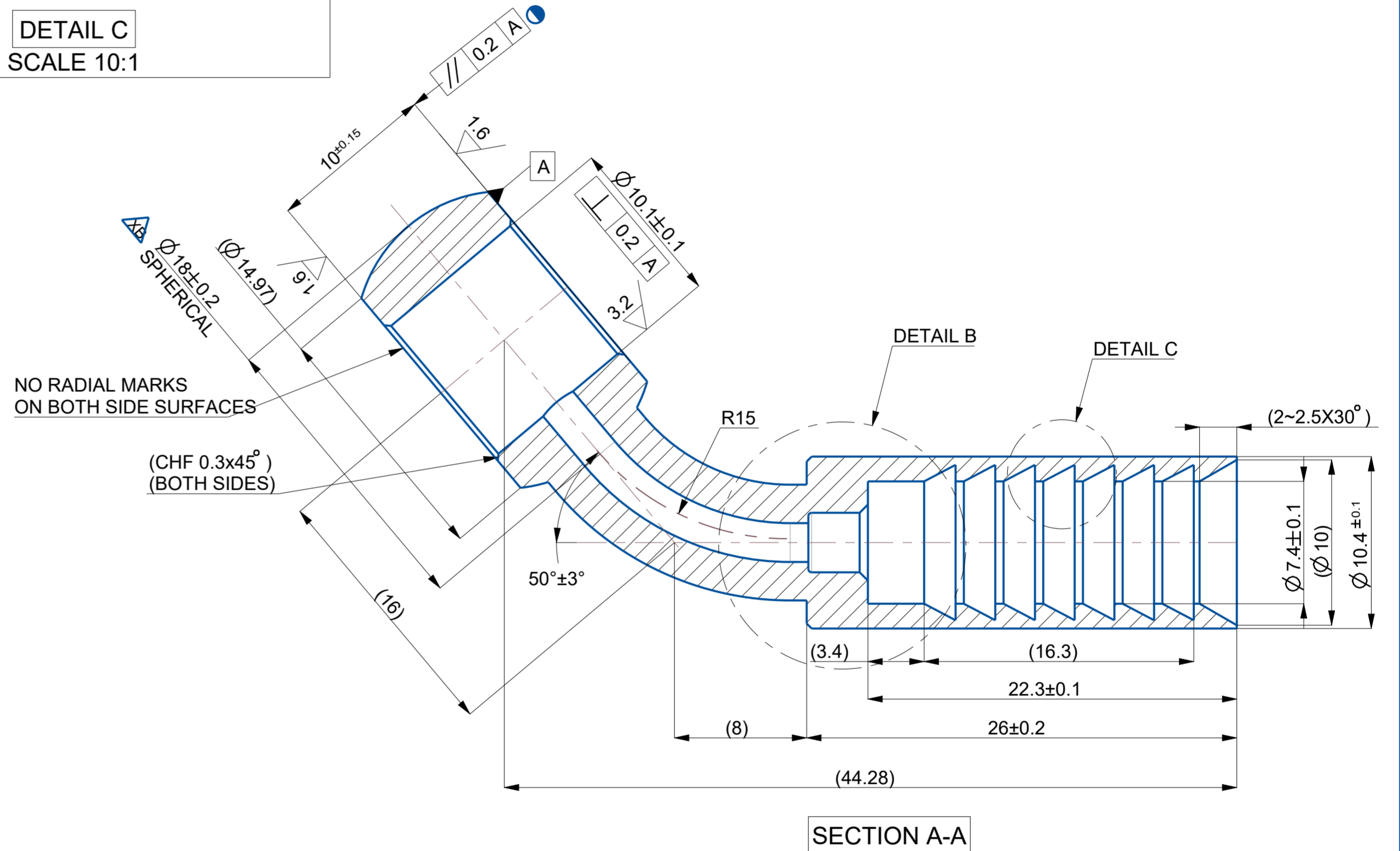

DETAIL B  
SCALE 6:1

- NOTES:**
1. SURFACE TREATMENT FOR END CONNECTOR: Fe/Zn (WHITE) AS PER ABS00010 TO BE DONE AFTER BRAZING.
  2. PART SHALL BE FREE FROM BURRS.
  3. ENSURE THAT OPENING OF DRILLED HOLE Ø 2.35 IN BANJO.
  4. ALL DIMENSIONS TO BE MEASURED AFTER PLATING.
  5. BRACKET ( ) DIMENSIONS ONLY FOR REFERENCE.

① = 1	SCALE: 4:1	MATERIAL: EN1A/15B25/C20	O.E.PART NO. NA
② = 0			RAW DWG/PART NO. NA
DRAWN RSP		PART NAME: END CONNECTOR-STEEL BRAIDED HOSE (M/CYL OR CALIPER SIDE) PROJECT- K1, K1R, K2	DRG.REV. XB
CHECKED SSS			DWG/PART NO. B2EH076020
APPROVED PMK			
TOLERANCES	DRAW WEIGHT: ----	FINISHED WEIGHT: 21 gms(approx)	
----	FINISH: REFER NOTES	HEAT TREATMENT:----	
		<b>ENDURANCE TECHNOLOGIES LTD.</b> BRAKING DIVISION	

SHAFTS Holes TO H7/D8 TO +

A2

SHEET SIZE

SIGNIFICANT

SAFETY

This drawing is a property of Endurance Technologies Ltd. and shall not be copied or reproduced without permission of the company. FIRST ANGLE PROJECTION PLEASE DO NOT SCALE THE DRAWING. ASK IF IN ANY DOUBT ALL DIMENSIONS IN mm