

Axle Hole Drill/Face/Ø12.1x45°C'Fer Tool



Daieton Engineers

CUSTOMER :-S.S.Industries

Drg.No.:-315803

REF DRG.:-

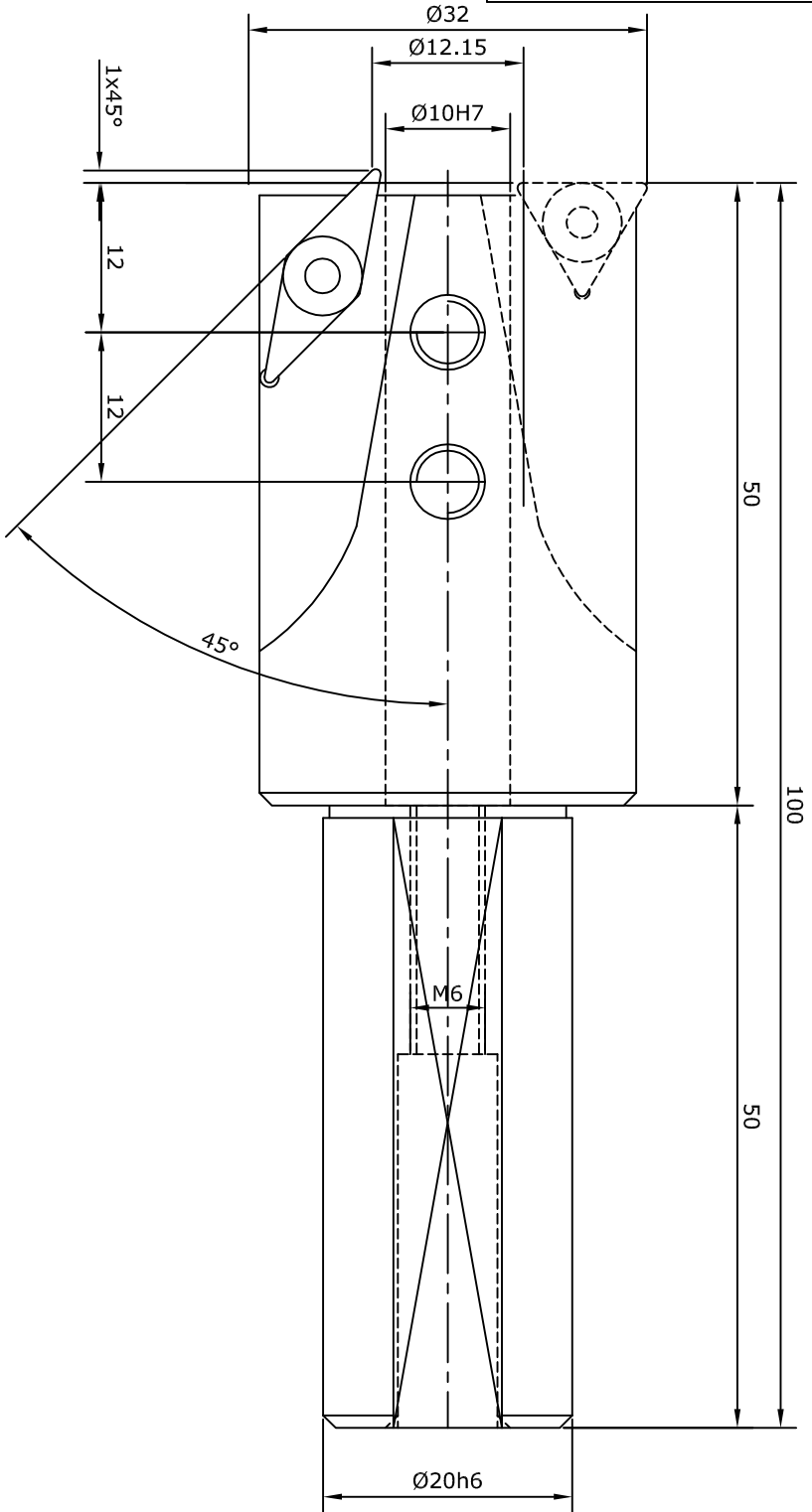

ON COMPONENT:-
01)Drill Size:-Ø12.1
02)C'Fer :-1x45°

PART NAME :-AXLE TOOL HOLDER

DRAWN BY :	DATE :	REV. NO.
PNN	26-03-2018	

CHEKD:

APPVED:



9		
8		
7		
6	Torx:-T7	01
5	Screw:-551302003	01
4	Insert:-TCGX110204	01
3	Insert:-VCGX110204	01
2	HARDNESS :- 42-46HRC	
1	MATERIAL :- EN47	
Sr.No.	DESCRIPTION	QTY.

DATE	REV	ALTERATIONS	ECN